



i.MX27 SOM-LV Hardware Specification

Hardware Documentation

Logic // Products
Published: July 2007
Last revised: May 2009

This document contains valuable proprietary and confidential information and the attached file contains source code, ideas, and techniques that are owned by Logic Product Development Company (collectively "Logic's Proprietary Information"). Logic's Proprietary Information may not be used by or disclosed to any third party except under written license from Logic Product Development Company.

Logic Product Development Company makes no representation or warranties of any nature or kind regarding Logic's Proprietary Information or any products offered by Logic Product Development Company. Logic's Proprietary Information is disclosed herein pursuant and subject to the terms and conditions of a duly executed license or agreement to purchase or lease equipment. The only warranties made by Logic Product Development Company, if any, with respect to any products described in this document are set forth in such license or agreement. Logic Product Development Company shall have no liability of any kind, express or implied, arising out of the use of the Information in this document, including direct, indirect, special or consequential damages.

Logic Product Development Company may have patents, patent applications, trademarks, copyrights, trade secrets, or other intellectual property rights pertaining to Logic's Proprietary Information and products described in this document (collectively "Logic's Intellectual Property"). Except as expressly provided in any written license or agreement from Logic Product Development Company, this document and the information contained therein does not create any license to Logic's Intellectual Property.

The Information contained herein is subject to change without notice. Revisions may be issued regarding changes and/or additions.

© Copyright 2009, Logic Product Development Company. All Rights Reserved.

Revision History

Rev	Editor	Revision Description	Schematic PN & REV	Approval	Date
1	ER	Internal Release	1005570 Rev 2.4	ER	07/27/07
2	JCA	<ul style="list-style-type: none"> - Section 1.2: updated Acronyms list. - Section 1.3: changed section heading to Scope of Document; updated text. - Section 2.2: corrected core clock speed to be 400 MHz instead of 532 MHz. - Throughout: Grammar and formatting changes. 	1005570 Rev 2.4	JCA	08/29/07
A	TED, JCA	<ul style="list-style-type: none"> -Section 1.1: Added "Product Overview" in lieu of product brief. -Section 2.1.1: Updated bullet list of Microcontroller features. -Section 2.3.5: Added Note about WEIM bus. -Section 2.5: Corrected serial interface pin number. -Section 3.5.1.2: Added Note about 5V input. -Section 5: Corrected J1 and J2 connector tables according to latest schematics; Changed all "NC" (No Connect) signals to "RFU" (Reserved for Future Use). -Section 6: Added section for "Mounting Specifications"; Updated all mechanical drawings.	1010966 Rev A	JCA	05/14/09

Please check www.logicpd.com for the latest revision of this manual, product change notifications, and additional documents.

Table of Contents

1	Introduction	1
1.1	Product Overview	1
1.2	Acronyms	1
1.3	Scope of Document	2
1.4	SOM-LV Interface	2
1.5	i.MX27 SOM-LV Block Diagram	3
1.6	Electrical, Mechanical, and Environmental Specifications	3
1.6.1	Absolute Maximum Ratings	3
1.6.1.1	Recommended Operating Conditions	4
2	Electrical Specification	5
2.1	Microcontroller	5
2.1.1	i.MX27 Microcontroller	5
2.1.2	i.MX27 Microcontroller Block Diagram	6
2.2	Clocks	6
2.3	Memory	7
2.3.1	Low Power DDR Synchronous DRAM	7
2.3.2	Direct Memory Access	7
2.3.3	NOR Flash	7
2.3.4	NAND Flash	7
2.3.5	PC Card Interface	7
2.4	10/100 Ethernet PHY	8
2.5	Audio Codec	8
2.6	Display Interface	8
2.7	Serial Interfaces	8
2.7.1	UARTA	8
2.7.2	UARTB	9
2.7.3	UARTC	9
2.7.4	CSPI	9
2.7.5	I2C	9
2.8	USB Interface	9
2.9	ADC/Touch Interface	9
2.10	General Purpose I/O	10
2.11	Onboard Logic Interfaces	10
2.12	Expansion/Feature Options	10
3	System Integration	11
3.1	Configuration	11
3.2	Resets	11
3.2.1	Master Reset (MSTR_nRST)—Reset Input	11
3.2.2	SOM-LV Reset (RESET_nOUT)—Reset output	11
3.3	Interrupts	12
3.4	JTAG Debugger Interface	12
3.5	Power Management	13
3.5.1	System Power Supplies	13
3.5.1.1	MAIN_BATTERY	13
3.5.1.2	5V	13
3.5.1.3	3.3V_IN	13
3.5.1.4	3.3V_uP_BATT	13
3.5.2	System Power Management	14
3.5.3	Microcontroller	14
3.5.3.1	Run State	14
3.5.3.2	Suspend State	14
3.5.3.3	Standby State	14
3.6	ESD Considerations	15

4	Memory & I/O Mapping	16
5	Pin Descriptions & Functions	17
5.1	J1 Connector 240-Pin Descriptions	17
5.2	J2 Connector 240-Pin Descriptions	25
6	Mechanical Specifications	31
6.1	Interface Connectors	31
6.2	Mounting Specifications	31
6.2.1	Support Spacers	31
6.2.2	Screw Size	31
6.2.3	Washers	31
6.3	i.MX27 SOM-LV Mechanical Drawings	31

Table of Figures

Figure 1.1: i.MX27 SOM-LV Block Diagram	3
Figure 2.1: i.MX27 Microcontroller Block Diagram.....	6
Figure 3.1: ARM JTAG Connector	12

1 Introduction

1.1 Product Overview

The i.MX27 System on Module (SOM) is a compact, product-ready hardware and software solution that fast forwards your embedded product design.

Designed in the SOM-LV form factor, the i.MX27 module offers essential features for handheld and embedded networking applications. Use of custom baseboards makes the SOM-LV the ideal foundation for OEMs developing handheld and compact products. The SOM-LV expansion connectors use a common reference pin-out scheme, which enables easy scalability to next generation microprocessor SOMs when new functionality or performance is required.

Application development is performed right on the product-ready i.MX27 SOM-LV and software Board Support Packages (BSPs), which enables you to seamlessly transfer your application code and hardware into production.

The i.MX27 SOM-LV is ideal for applications in the medical, point-of-sale, industrial, and security markets. From patient monitoring and medical imaging, to card payment terminals and bar code readers, to CCTV cameras and intruder alarms, the i.MX27 SOM-LV allows for powerful versatility and long-life products.

1.2 Acronyms

ADC	Analog to Digital Converter
BSP	Board Support Package
BTB	Board-to-Board
CCM	Clock Controller Module
CSPI	Configurable Serial Peripheral Interface
DDR	Double Data Rate (RAM)
DMA	Direct Memory Access
ECB	Event Control Block
ESD	Electrostatic Discharge
FIFO	First In First Out
GPIO	General Purpose Input Output
GPO	General Purpose Output
HR-TFT	High Reflective-Thin Film Transistor (LCD)
I2C	Inter-Integrated Circuit
I2S	Inter-Integrated Circuit Sound
IC	Integrated Circuit
IDC	Insulation Displacement Connector
I/O	Input/Output
IRQ	Interrupt Request
ISA	Industry Standard Architecture
LCD	Liquid Crystal Display
LDO	Low Dropout (Regulator)
LoLo	LogicLoader™
OTG	On-the-Go (USB)
PCB	Printed Circuit Board
PCMCIA	Personal Computer Memory Card International Association (PC Cards)
PHY	Physical Layer
PLL	Phase Lock Loop
PWM	Pulse Width Modulation
RTC	Real Time Clock
SDIO	Secure Digital Input Output

SDRAM	Synchronous Dynamic Random Access Memory
SOM	System on Module
SSI	Synchronous Serial Interface
SSP	Synchronous Serial Port
SPI	Standard Programming Interface
STN	Super-Twisted Nematic (LCD)
TFT	Thin Film Transistor (LCD)
TSC	Touch Screen Controller
TTL	Transistor-Transistor Logic
UART	Universal Asynchronous Receive Transmit
WEIM	Wireless External Interface Module

1.3 Scope of Document

This Hardware Specification is unique to the design and use of the i.MX27 SOM-LV as designed by Logic and does not intend to include information outside of that scope. Detailed information about the Freescale i.MX27 processor or any other device component on the SOM can be found in their respective manuals and specification documents. Specific documents mentioned within this Hardware Specification include:

- *LogicLoader User's Manual* (available from Logic at <http://support.logicpd.com/auth/downloads/i.MX27/>)
- *i.MX27 SOM-LV Schematics* (available from Logic at <http://support.logicpd.com/auth/downloads/i.MX27/>)
- *i.MX27 Reference Manual* (available from Freescale at <http://www.freescale.com/iMX>)
- *i.MX27 Data Sheet* (available from Freescale at <http://www.freescale.com/iMX>)
- *MC13783 Data Sheet* (available from Freescale at www.freescale.com/webapp/sps/site/prod_summary.jsp?code=MC13783&nodeld=0174404881)
- *USB 2.0 Specification* (available from USB.org at <http://www.usb.org/developers/docs/>)

1.4 SOM-LV Interface

Logic's common SOM-LV interface allows for easy migration to new processors and technology. Logic is constantly researching and developing new technologies to improve performance, lower cost, and increase feature capabilities. By using the common SOM-LV footprint, it is possible to take advantage of Logic's work without having to re-spin the old design. Contact Logic sales for more information.

In fact, encapsulating a significant amount of your design onto the SOM-LV reduces any long-term risk of obsolescence. If a component on the SOM-LV design becomes obsolete, Logic will simply design for an alternative part that is transparent to your product. Furthermore, Logic tests all SOMs prior to delivery, decreasing time-to-market and ensuring a simpler and less costly manufacturing process.

1.5 i.MX27 SOM-LV Block Diagram

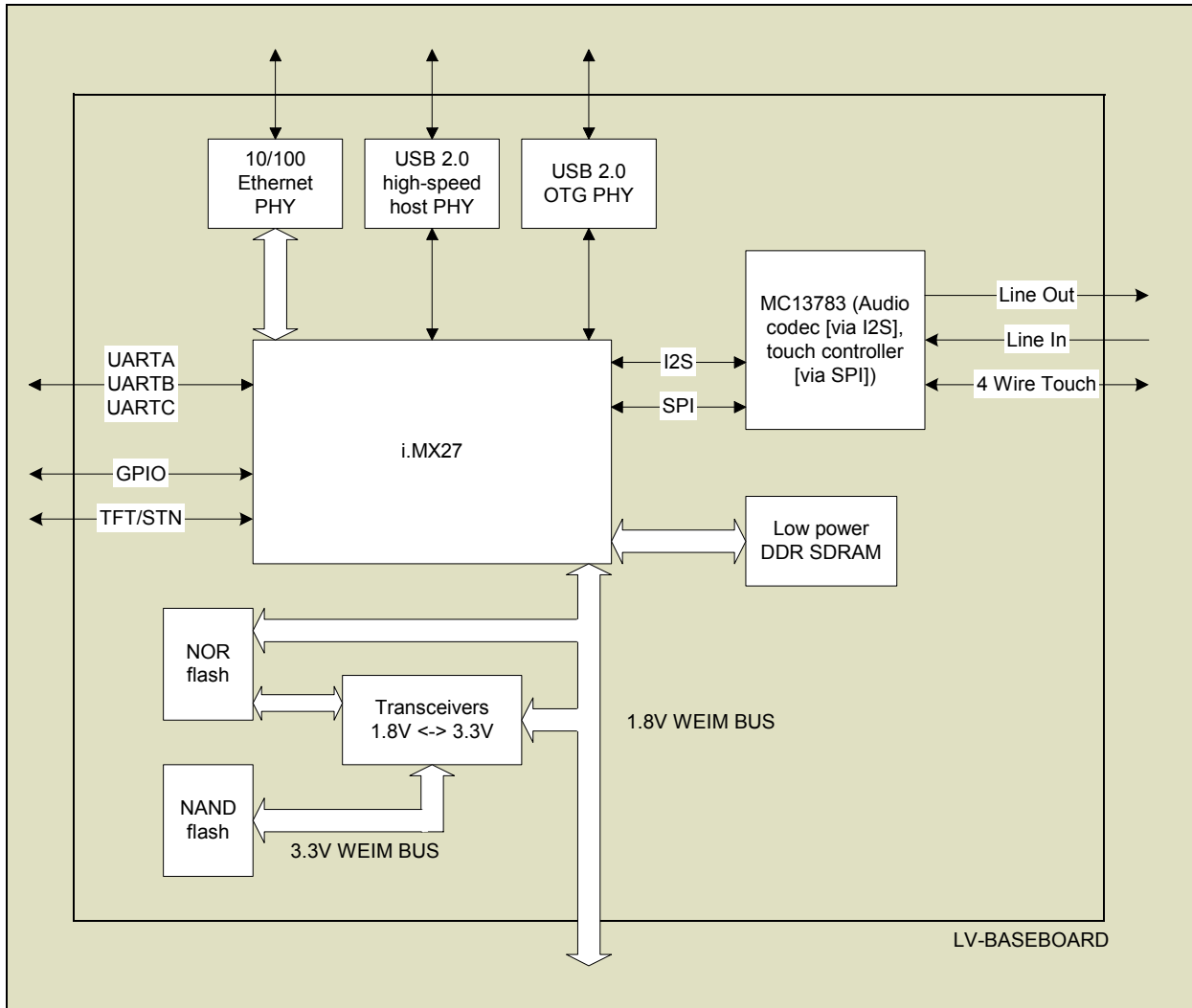

Figure 1.1: i.MX27 SOM-LV Block Diagram

1.6 Electrical, Mechanical, and Environmental Specifications

1.6.1 Absolute Maximum Ratings

Parameter	Symbol	Rating	Unit
DC 3.3 V Supply Voltage	3.3V_IN	VSS-0.3 to 3.6	V
DC Main Battery Input Voltage	MAIN_BATTERY	VSS-0.3 to 4.65	V
RTC Backup Battery Voltage	3.3V_uP_BATT	VSS-0.3 to 4.65	V

NOTE: These stress ratings are only for transient conditions. Operation at, or beyond, absolute maximum rating conditions may affect reliability and cause permanent damage to the SOM-LV and its components.

1.6.1.1 Recommended Operating Conditions

Parameter	Min	Typical	Max	Unit	Notes
DC Main Battery Input Voltage	2.7	3.3	4.2	V	
DC Main Battery Active Current	—	—	—	mA	
DC Main Battery Suspend Current	—	—	—	mA	
DC Main Battery Standby Current	—	—	—	mA	
DC 3.3 V Voltage	3.0	3.3	3.6	V	
DC 3.3 V Active Current	—	—	—	mA	
DC 3.3 V Suspend Current	—	—	—	mA	
DC 3.3 V Standby Current	—	—	—	mA	
Commercial Operating Temperature	0	25	70	°C	
Storage Temperature	-40	25	85	°C	
Dimensions	—	50.8 x 76.2 x 7.9	—	mm	
Weight	—	25.5	—	Grams	2
Connector Insertion/Removal	—	50	—	Cycles	
Input Signal High Voltage	0.7 x VREF	—	VREF	V	3
Input Signal Low Voltage	GND	—	0.3 x VREF	V	3
Output Signal High Voltage	0.8 x VREF	—	VREF	V	3
Output Signal Low Voltage	GND	—	0.2 x VREF	V	3

NOTES:

1. General note: CPU power rails are sequenced on the module.
2. May vary depending on SOM-LV configuration.
3. VREF represents the peripheral I/O supply reference for the specific CPU voltage rail.

2 Electrical Specification

2.1 Microcontroller

2.1.1 i.MX27 Microcontroller

The i.MX27 SOM-LV uses Freescale's highly integrated i.MX27 processor. This device features the ARM926EJ-S core and provides many integrated on-chip peripherals, including:

- Integrated ARM926EJ -S Core
 - 32-bit ARM 9 core
 - 16 Kbytes instruction cache
 - 16 Kbytes data L1 cache
- Integrated LCD Controller
 - Up to 800 x 600 x 18 bit color
- Three UARTs
- I2S codec interface
- One high-speed USB 2.0 On-the-Go (OTG) controller and one USB 2.0 host interfaces
- Many general purpose I/O (GPIO) signals
- 16 independent DMA channels
- Programmable timers
- Real time clock (RTC)
- Low power modes

See Freescale's *MCIMX27 Reference Manual* and *i.MX27 Data Sheet* for additional information.
www.freescale.com/iMX

IMPORTANT NOTE: Please visit www.freescale.com/iMX for errata on the i.MX27.

2.1.2 i.MX27 Microcontroller Block Diagram

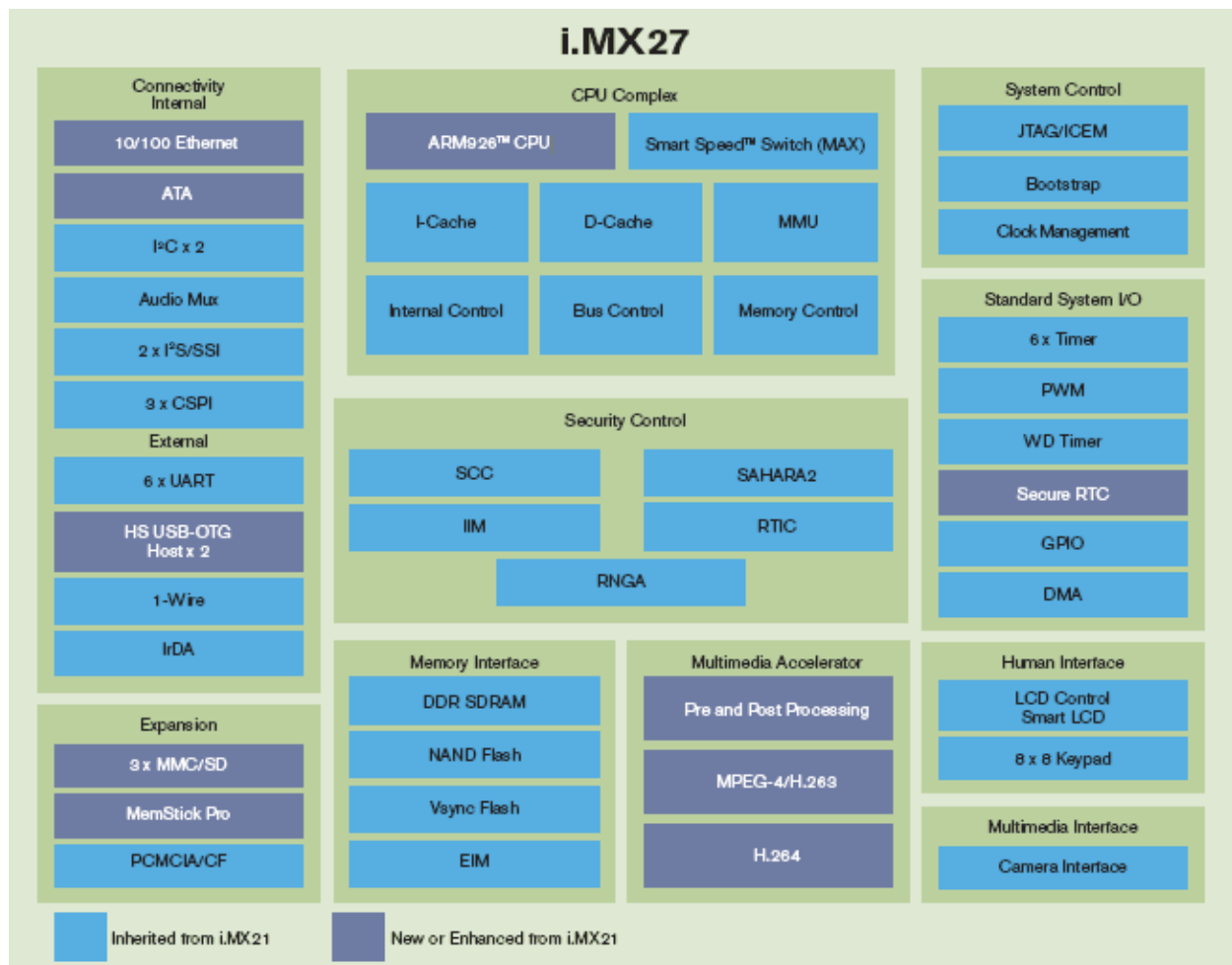

Figure 2.1: i.MX27 Microcontroller Block Diagram

2.2 Clocks

The i.MX27 requires an oscillator and crystal to enable proper internal timing. A 26.000 MHz oscillator is used to generate many of the processor's internal clocks via a series of Phase Lock Loops (PLLs) and signal dividers. To generate the core CPU clock, the 26.000 MHz signal is run through a Digital PLL controlled by the Clock Controller Module (CCM) register. Divisors are used to divide down the internal bus frequency to set the LCD, memory controller, camera interface, etc.

IMPORTANT NOTE: Please see Freescale's *i.MX27 Reference Manual* for additional information about processor clocking.

The second required crystal runs at 32.768 kHz. The 32.768 kHz clock is used for processor start up and as a reference clock for the Real Time Clock (RTC) Module.

The i.MX27's microcontroller core clock speed is initialized by software on the SOM-LV. The SDRAM bus speed is set at 133 MHz in LogicLoader. Other clock speeds, such as core speed and specific serial baud rates, can be supported and modified in software for specific user applications.

The i.MX27 SOM-LV provides an external bus clock, uP_BUS_CLK. The uP_BUS_CLK, which is connected to the processor's BCLK pin, is disabled by default. uP_SDCLK and uP_nSDCLK serve as the DDR RAM clocks on the i.MX27 SOM-LV.

i.MX27 Microcontroller Signal Name	i.MX27 SOM-LV Net Name	Default Software Value in LogicLoader
CORE	N/A	Up to 400 MHz
SDCLK	uP_SDCLK	133 MHz
SDCLK_B	uP_nSDCLK	133 MHz
BLCK	uP_BUS_CLK	Not configured

2.3 Memory

2.3.1 Low Power DDR Synchronous DRAM

The i.MX27 SOM-LV uses a 32-bit memory bus to interface to low power DDR SDRAM. The memory can be configured as 64 or 128 MB in order to meet the user's memory requirements and cost constraints. Logic's default memory configuration on the SOM-LV included in the Development Kit is specified as 128 MB.

2.3.2 Direct Memory Access

The Freescale i.MX27 microcontroller has a direct memory access controller which contains multiple Direct Memory Access (DMA) channels (16) for use with internal peripherals to achieve highly efficient data throughput. For more information on using the DMA interface, please refer to the *i.MX27 Reference Manual*.

2.3.3 NOR Flash

The i.MX27 SOM-LV uses a 16-bit memory bus to interface to NOR flash memory chips. The onboard SOM-LV memory can be configured as 2 or 4 MB to meet the user's flash requirements and cost constraints. Logic's default flash configuration is 2 MB on the SOM-LV included in the standard Development Kit. Because flash is one of the most expensive components on the i.MX27 SOM-LV, it is important to contact Logic when determining the necessary flash size for final product configuration. NAND flash is a lower cost alternative that should be considered for final product configuration.

It is possible to expand the system's non-volatile storage capability by adding external flash ICs, SD memory, CompactFlash, or NAND flash. See the i.MX27 Development Kit for reference designs or contact Logic for other possible peripheral designs.

2.3.4 NAND Flash

The i.MX27 SOM-LV uses an 8-bit memory bus to interface to NAND flash. The product supports configurations of 16, 32, 64 MB, and other sizes, depending on NAND availability. The SOM-LV included in the standard Development Kit contains 64 MB of NAND flash. Please contact Logic for more information.

2.3.5 PC Card Interface

The i.MX27 SOM-LV CPU directly supports a single PCMCIA or CompactFlash slot. The i.MX27 SOM-LV uses internal logic to provide the necessary signals for a PC Card interface. The development kit reference design includes a hot-swappable CompactFlash connector. Additional

CompactFlash slots can be added using the WEIM bus. Contact platformsupport@logicpd.com for more information on implementing additional slots.

NOTE: Adding long latency devices to the WEIM bus can delay accesses to the SDRAM because of shared controlled signals.

2.4 10/100 Ethernet PHY

The i.MX27 SOM-LV uses an SMSC 8700 Ethernet PHY to provide an easy-to-use networking interface. The four analog PHY interface signals (transmit/receive) each require an external impedance matching circuit to operate properly. Logic provides an example circuit schematic in the i.MX27 Development Kit for reference. Please note the TX+/- and RX+/- pairs must be routed as differential pairs on the baseboard PCB.

2.5 Audio Codec

The i.MX27 processor has a Synchronous Serial Interface (SSI) controller that can support AC97 and I2S formats. This SSI controller implements a 4-pin serial interface to the I2S audio codec, in this case the Freescale MC13783. From the codec on the i.MX27 SOM-LV, the outputs are CODEC_OUTL and CODEC_OUTR. These signals are available from the expansion connectors.

The codec on the i.MX27 SOM-LV performs up to full-duplex codec functions and supports variable sample rates from 8k–96k samples per second.

NOTE: The Freescale i.MX27 SOM-LV also offers an SSI interface for other codec devices. This interface provides a digital interface that is multiplexed with the signals from the SSI controller. If you are looking for a different codec option, Logic has previously interfaced different high-performance audio codecs into other SOMs. Contact Logic for assistance in selecting an appropriate audio codec for your application.

2.6 Display Interface

Freescale's i.MX27 microcontroller has a built-in LCD controller supporting STN, color STN, HR-TFT, and TFT panels at up to 800 x 600 x 18-bit color resolution. See the *i.MX27 Reference Manual* for further information on the integrated LCD controller. The signals from the i.MX27 LCD controller are organized by bit and color and can be interfaced through the expansion connectors. Logic has written drivers for numerous panels of different types and sizes. Please contact Logic before selecting a panel for your application.

IMPORTANT NOTE: Using the internal graphics controller will affect processor performance. Selecting display resolutions and color bits per pixel will vary processor busload.

2.7 Serial Interfaces

The i.MX27 SOM-LV comes with the following serial channels: UARTA, UARTB, UARTC, CSPI, and two I2C ports. If additional serial channels are required, please contact Logic for reference designs. Please see the *i.MX27 Reference Manual* for further information regarding serial communications.

2.7.1 UARTA

UARTA has been configured to be the i.MX27 Development Kit's main serial port. It is an asynchronous 16C550-compatible UART. This UART provides a high-speed serial interface that uses First In / First Out (FIFO) and is capable of sending and receiving serial data simultaneously. The signals from the SOM-LV are Transistor-Transistor Logic (TTL) level signals,

not RS232 level signals. The user must provide an external RS232 transceiver for RS232 applications. Logic has provided an example reference design with the Development Kit. When choosing an RS232 transceiver, the user should keep in mind cost, availability, ESD protection, and data rates.

The UARTA baud rate is set by default to 115.2 Kbits/sec, though it supports most common serial baud rates.

2.7.2 UARTB

Serial Port UARTB is an asynchronous 16C550-compatible UART. This UART is a high-speed serial interface that uses FIFO and is capable of sending and receiving serial data simultaneously. The signals from the SOM-LV are TTL level signals, not RS232 level signals. The UARTB baud rate can also be set to most common serial baud rates.

2.7.3 UARTC

Like UARTB, Serial Port UARTC is an asynchronous 16C550-compatible UART. This UART is a high-speed serial interface that uses FIFO and is capable of sending and receiving serial data simultaneously. The signals from the SOM-LV are TTL level signals, not RS232 level signals. The UARTC baud rate can also be set to most common serial baud rates.

2.7.4 CSPI

The Configurable Serial Peripheral Interface (CSPI) is used on the SOM-LV to communicate with the onboard EEPROM and MC13783 codec. There are two chip selects available to the user. Please see the *i.MX27 Reference Manual* for further information.

2.7.5 I2C

The i.MX27 SOM-LV supports two external I2C ports. The clock and data signals for both ports have 4.7K pull-up resistors to their respective power rails. Please see the *i.MX27 Reference Manual* for further information.

2.8 USB Interface

The i.MX27 SOM-LV supports one USB 2.0 high-speed host port and one USB 2.0 OTG port which can function as a host or device/client. Both ports can operate at up to 480 Mbit/sec. The processor has the USB controller internal to the device for both the host and OTG port. The SOM-LV has external PHYs to support both interfaces. The PHYs are SMSC USB3311 devices. For more information on using both the USB host and OTG interfaces, please see the *i.MX27 Reference Manual*.

IMPORTANT NOTE: In order for USB to be correctly implemented on the i.MX27 SOM-LV, additional impedance matching circuitry may be required on the USB_x_D+ and USB_x_D- signals before they can be used. USB 2.0 requirements specify the signals must be routed as differential pairs with a 90 ohm differential impedance. Refer to the *USB 2.0 Specification* for detailed information.

2.9 ADC/Touch Interface

The i.MX27 SOM-LV uses the MC13783 integrated touch screen controller (TSC). The controller includes a 13-bit analog-to-digital converter (ADC). This TSC is used to support standard 4-wire resistive touch panels. The TSC has 6 A/D signals that are available externally off the connectors.

The device is connected to the CPU by the CSPI interface. Please see the *MC13783 Datasheet* for more information.

2.10 General Purpose I/O

Logic designed the i.MX27 SOM-LV to be flexible and provide multiple options for analog and digital GPIO. There are numerous digital GPIO pins on the SOM-LV that interface to the i.MX27 processor. See the “Pin Descriptions & Functions” Section of this Hardware Specification for more information. If certain peripherals are not desired, such as the LCD controller, chip selects, IRQs, or UARTS, then multiple GPIO pins become available.

2.11 Onboard Logic Interfaces

The onboard logic interfaces are used to create additional functionality on the SOM-LV with the support of a few discrete logic components. The logic interface provides memory map selection between multiple chips as well as buffer direction and output control.

Memory Map

The onboard logic creates a 2-area memory map from one CPU chip select. When chip select 4 is asserted and A23 is low, onboard logic asserts the LATCH_nCS signal, which is the onboard LATCH GPO enable. Asserting chip select 4 low and A23 high asserts the FAST_nCS signal, which goes off-board for customer use.

Chip Select	Offset	Device/Feature	Notes
nCS4	+ 0x00	LATCH_nCS	GPO control
nCS4	+ 0x01000000	FAST_nCS (customer use)	Offset is accurate when CS4 is setup for 16 bit accesses

2.12 Expansion/Feature Options

The i.MX27 SOM-LV was designed for expansion and a variable feature set, providing all the necessary control signals and bus signals to expand the user’s design. Some of these signals are buffered and brought out to the expansion connectors. It is possible for a user to expand the SOM-LV’s functionality even further by adding host bus or ISA bus devices. Some features that are implemented on the i.MX27, but are not discussed herein, include: RTC, pulse width modulation (PWM), Secure Digital, SDIO cards, MPEG encoder/decoder, Image Processing Unit, 1wire interface, ATA interface, and the debug module. See the *i.MX27 Reference Manual* and the *i.MX27 SOM-LV Schematics* for more details. Logic has experience implementing additional options, including other audio codecs, wireless ICs, co-processors, and components on SOMs and baseboards. Please contact Logic for potential reference designs before selecting your peripherals.

3 System Integration

3.1 Configuration

The i.MX27 SOM-LV was designed to meet multiple applications for users with specific design and budget requirements. As a result, this SOM-LV supports a variety of embedded operating systems and supports the following hardware configurations:

- Flexible memory footprint: 64 or 128 MB low power DDR SDRAM
- Flexible NOR flash footprint: 0, 2, or 4 MB NOR flash
- Flexible NAND flash footprint: 0, 16, 32, 64 MB, or larger NAND flash
- Optional SMSC LAN8700 10/100 Ethernet PHY

Some of these configurations are only available as custom model numbers under terms of Logic's Custom Module NPI Process. Please contact Logic Sales for details: product.sales@logicpd.com.

3.2 Resets

The SOM-LV has a reset input (MSTR_nRST) and a reset output (RESET_nOUT). External devices use MSTR_nRST to assert reset to the product. The SOM-LV uses RESET_nOUT to indicate to other devices that the SOM-LV is in reset.

3.2.1 Master Reset (MSTR_nRST)—Reset Input

Logic suggests that custom designs implementing the i.MX27 SOM-LV use the MSTR_nRST signal as the “pin hole” reset used in commercial embedded systems. The MSTR_nRST triggers a power-on-reset event to the i.MX27 processor and resets the entire CPU.

IMPORTANT NOTE: Any custom reset circuit design should guard the assertion of the reset lines during a low power state so as to prevent power-up in a low or bad power condition. (Powering-up in a low or bad power condition will cause data corruption and possible temporary system lockup). See the “Power Management” Section for further details. Either one of the following two conditions will cause a system-wide reset: power on the MSTR_nRST signal or a low pulse on the MSTR_nRST signal.

Low Pulse on MSTR_nRST Signal:

A low pulse on the MSTR_nRST signal of the reset chip, asserted by an external source (for example, the reset button on the custom design application) will bring MSTR_nRST low until the assertion source is de-asserted. There is no delay beyond the de-assertion of the external MSTR_nRST signal source, so the custom design must ensure that the assertion time is sufficient for all related peripherals.

Logic suggests that for any external assertion source that triggers the MSTR_nRST signal, analog or digital, de-bouncing should be used to generate a clean, one-shot reset signal.

3.2.2 SOM-LV Reset (RESET_nOUT)—Reset output

All hardware peripherals should connect their hardware-reset pin to the RESET_nOUT signal on the expansion connector. Internally, all SOM-LV peripheral hardware reset pins are connected to the RESET_nOUT net.

If the output of the onboard voltage-monitoring circuit is asserted (active low), the user can expect to lose information stored in RAM. The data loss occurs because the CPU is reset to its reset defaults.

3.3 Interrupts

The i.MX27 incorporates the ARM926EJ-S Interrupt Controller (AIC) which provides up to 64 interrupt sources to the ARM core. Refer to Freescale's *i.MX27 Reference Manual* for further information on using interrupts.

3.4 JTAG Debugger Interface

The JTAG connection on the i.MX27 SOM-LV allows recovery of corrupted flash memory and real-time application debug. There are several third-party JTAG debuggers available for Freescale microcontrollers. The following signals make up the JTAG interface to the i.MX27 processor: TDI, TMS, TCK, TDO, nTRST, RTCK, MSTR_nRST, and nDE. These signals should interface directly to a 20-pin 0.1" through-hole connector, as shown on the LV-Baseboard reference schematics (see Figure 3.1).

IMPORTANT NOTE: When laying out the 20-pin connector, realize it may not be numbered as a standard 20-pin 0.1" insulation displacement connector (IDC) through-hole connector. See i.MX27 Development Kit reference design for further details. Each JTAG tool vendor may define the 20-pin IDC connector pin-out differently.

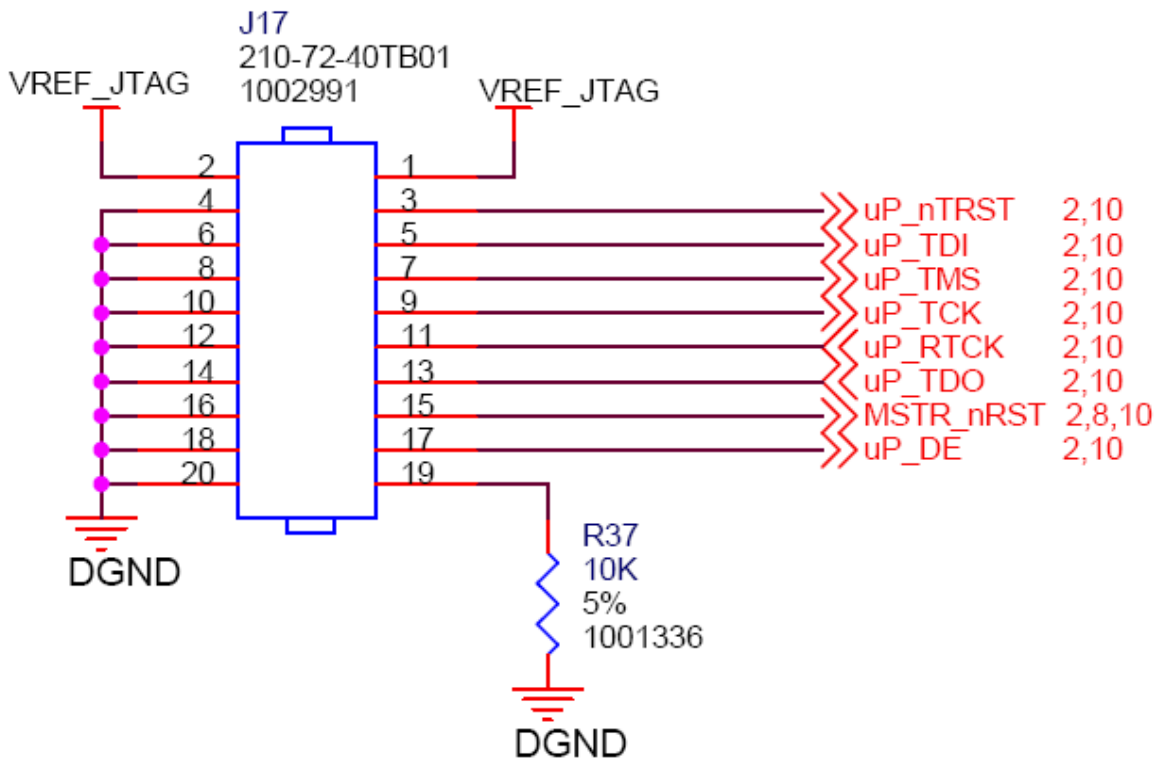

Figure 3.1: ARM JTAG Connector

3.5 Power Management

3.5.1 System Power Supplies

In order to ensure a flexible design, the i.MX27 SOM-LV has the following power areas: MAIN_BATTERY, 5V, 3.3V_IN, 3.3V_uP_BATT. All power areas are inputs to the SOM-LV. The module also provides reference voltages to specific peripheral areas. Reference voltages are named VREF_xxxx on the expansion connectors, are outputs from the SOM-LV, and should be used as reference voltage inputs to level shifting devices on baseboard designs.

3.5.1.1 MAIN_BATTERY

The MAIN_BATTERY input is the main source of power for the SOM-LV. This input expects a voltage within typical single lithium-ion battery limits which generally operate from 2.7 V to 4.2 V. If a lithium-ion battery is not used as the main power source, it is recommended to supply a fixed 3.3 V supply. The MC13783 power management controller takes the MAIN_BATTERY rail input and creates all onboard voltages. If the design is required to maintain RAM contents in a critical power situation (e.g., low battery, loss of power), the MAIN_BATTERY supply should be maintained above the minimum level at all costs (see Section 2 “Electrical Specification”). Logic suggests using Standby mode to prepare the system for a critical power condition. In this way, the SDRAM is placed into self-refresh and the processor is placed into the Standby state. (Please note the description of Standby mode in Section 3.5.3.3 below.) This supply must stay within the acceptable levels specified in Section 2, “Electrical Specification,” unless experiencing power down or critical power conditions.

3.5.1.2 5V

The 5V input is only used when the charge path components are populated on the SOM-LV. The default population options do not provide a charge path circuit on the module. The optional charge path circuits allow in-system charging of the lithium-ion battery source when a 5 V power is supplied to the 5 V supply. Most designs will require a separate battery charging circuit on the baseboard to charge the main battery source.

NOTE: If you have a custom i.MX27 SOM-LV that populates the charging circuitry, this 5V input should be supplied through a 5V supply on the baseboard. Custom configuration SOM-LVs are only available through the official Custom Module NPI Process. Please contact Logic Sales for more information about the Custom Module NPI Process: product.sales@logicpd.com.

3.5.1.3 3.3V_IN

The 3.3V_IN rail is used to power a few legacy devices on the SOM-LV which require 3.3 V. The baseboard should provide 3.3 V to the SOM-LV. Typically this is implemented as a low dropout (LDO) or switching regulator connected to the MAIN_BATTERY power source. This supply must stay within the acceptable levels specified in Section 2, “Electrical Specification” unless experiencing power down or critical power conditions. Under critical power conditions, Logic suggests notifying the system through the assertion of a Standby sequence first, and then powering this supply off.

3.5.1.4 3.3V_uP_BATT

The 3.3V_uP_BATT power rail is used to power the onboard RTC and power management state machine internal to the MC13783 power management controller. Always power this rail to maintain the clock and power state of the product. A lithium-ion coin cell typically supplies power to this rail. The MC13783 overrides this input when MAIN_BATTERY is applied.

3.5.2 System Power Management

Good power management design is important in any system development and embedded system design is no exception. In embedded system design, power management is typically one of the most complicated areas due to the dramatic effect it has on product cost, performance, usability, and overall customer satisfaction. Many factors affect a power-efficient hardware design: power supply selection (efficiency), clocking design, IC and component selection, etc. The i.MX27 SOM-LV was designed with these aspects in mind while also providing maximum flexibility in software and system integration.

On the i.MX27 there are many different software configurations that drastically affect power consumption: microcontroller core clock frequency, bus clock frequency, peripheral clocks, bus modes, power management states (Run, Wait, Doze, State Retention, and Deep Sleep); peripheral power states and modes; product user scenarios; interrupt handling; and display settings (resolution, backlight, refresh, bits per pixel, etc). These settings are typically initialized in the startup software routines and may be modified later in the operating system and application software. Information for these items can be found in the appropriate documents such as the *LogicLoader User's Manual* or the specific BSP manual.

3.5.3 Microcontroller

The i.MX27 processor power management's scheme was designed to be easy to use. There are five power management modes provided in the i.MX27 microcontroller: Run, Wait, Doze, State Retention, and Deep Sleep. Logic Product Development BSPs have simplified the power management scheme to three power states: Run, Suspend, and Standby. Please see the descriptions of all three states below, as well as Freescale's *i.MX27 Reference Manual*, for more details.

3.5.3.1 Run State

Run is the normal operating state for the i.MX27 SOM-LV in which oscillator inputs and all clocks are hardware enabled. The i.MX27 can enter Run mode from any state. A Standby-to-Run transition occurs on any valid wakeup event, such as the assertion of MSTR_nRST or any enabled interrupt signal. All required power supplies are active in this state. Please see Freescale's *i.MX27 Reference Manual* for further information.

3.5.3.2 Suspend State

Suspend is the hardware power-down state for the i.MX27 SOM-LV, allowing for lower power consumption. The Suspend state is designed to reduce power consumption while the i.MX27 is waiting for an event, such as a keyboard input. In Logic BSPs, the Suspend state is entered by asserting the nSUSPEND signal or through software. The Wait, Doze, or State Retention power state is entered. All power supplies remain active and system context is retained. An internal or external wakeup event can cause the processor to transition back to Run mode. Please see Freescale's *i.MX27 Reference Manual* for further information.

3.5.3.3 Standby State

Standby is the lowest power state for the i.MX27 SOM-LV. This state is entered in Logic BSPs by asserting the nSTANDBY signal or through software. The i.MX27 processor is put into Stop state and all clocks are stopped. The MAIN_BATTERY power rail should be maintained if the low power DDR SDRAM contents wish to be retained. Internal or external wakeup events can cause a return to the Run state.

3.6 ESD Considerations

The i.MX27 SOM-LV was designed to interface to a customer's peripheral board, while remaining low cost and adaptable to many different applications. The SOM-LV does not provide any onboard ESD protection circuitry—this must be provided by the product it is used in. Logic has extensive experience in designing products with ESD requirements. Please contact Logic if you need any assistance in ESD design considerations.

4 Memory & I/O Mapping

On the Freescale i.MX27 microcontroller, all address mapping for the Wireless External Interface Module (WEIM) and external chip selects is fixed. Please consult Freescale's *i.MX27 Reference Manual* for details.

DDR RAM and shared WEIM Bus

Mapped "Chip Select" signals for the FlexBus are available as outputs from the microcontroller and are assigned as follows:

CS0 = NOR flash

CS1 = Available for use by an off-board external device (uP_nCS_A_EXT)

CS2/CSD0 = DDR SDRAM chip select 0

CS3/CSD1 = Available for use by an off-board external device (uP_nCS_B_EXT)

CS4 = Shared area: GPO access when A23 is low, off-board external use when A23 is high (FAST_nCS)

CS5 = Off-board signal available for external use. (SLOW_nCS)

Please consult the *LogicLoader User's Manual* and the *LogicLoader User's Manual Addendum* for the i.MX27 for complete memory map information.

5 Pin Descriptions & Functions

IMPORTANT NOTE: The following pin descriptions and states are described after the initialization of LogicLoader (bootloader). Many of the signals defined in the tables below can be configured as input or outputs—all GPIOs on the i.MX27 can be configured as either inputs or outputs—and have different functions. It is critical to review all signals in the final design (both electrical and software) to verify the necessary configuration (external pull-ups/pull-downs).

5.1 J1 Connector 240-Pin Descriptions

J1 Pin#	Signal Name	I/O	Voltage	Description
1	RFU	I/O	NA	Reserved for future use. Do not connect.
2	RFU	I/O	NA	Reserved for future use. Do not connect.
3	RFU	I/O	NA	Reserved for future use. Do not connect.
4	RFU	I/O	NA	Reserved for future use. Do not connect.
5	RFU	I/O	NA	Reserved for future use. Do not connect.
6	RFU	I/O	NA	Reserved for future use. Do not connect.
7	RFU	I/O	NA	Reserved for future use. Do not connect.
8	RFU	I/O	NA	Reserved for future use. Do not connect.
9	RFU	I/O	NA	Reserved for future use. Do not connect.
10	RFU	I/O	NA	Reserved for future use. Do not connect.
11	DGND	I	GND	Ground. Connect to digital ground.
12	DGND	I	GND	Ground. Connect to digital ground.
13	uP_nWAKEUP	I	1.8V	Active low. Software can use this signal as an interrupt to transition to RUN state from lower power states. Software is required for proper operation. This signal has a 10K pull-up.
14	ETHER_TX+	O	3.3V	This output pair drives 10/100 Mb/s Manchester-encoded data to the 10/100 BASE-T transmit lines. Route as differential pair with ETHER_TX(-). Requires external magnetics. See example LV-Baseboard designs for reference components.
15	nSUSPEND	I	2.7V	Active low. Software can use this signal to enter low power states from RUN mode. Software is required for correct operation. This signal has a 10K pull-up.
16	ETHER_TX-	O	3.3V	This output pair drives 10/100 Mb/s Manchester-encoded data to the 10/100 BASE-T transmit lines. Route as differential pair with ETHER_TX(+). Requires external magnetics. See example LV-Baseboard designs for reference components.
17	nSTANDBY	I	2.7V	Active low. Software can use this signal to enter low power states from RUN mode. Software is required for correct operation. This signal has a 10K pull-up.
18	ETHER_RX+	I	3.3V	This input pair receives 10/100 Mb/s Manchester-encoded data from the 10/100 BASE-T receive lines. Route as differential pair with ETHER_RX(-). Requires external magnetics. See example LV-Baseboard designs for reference components.
19	USB1_ID	I/O	5.0V	Tie to pin four of a USB 2.0 OTG compliant connector. This signal negotiates host/device operation with an external USB product. See example LV-Baseboard designs for reference components.

i.MX27 SOM-LV Hardware Specification

J1 Pin#	Signal Name	I/O	Voltage	Description
20	ETHER_RX-	I	3.3V	This input pair receives 10/100 Mb/s Manchester-encoded data from the 10/100 BASE-T receive lines. Route as differential pair with ETHER_RX(+). Requires external magnetics. See example LV-Baseboard designs for reference components.
21	USB1_VBUS	I	5.0V	Ties to pin one of a USB 2.0 OTG compliant connector. This signal indicates to the USB controller that an external USB Host has been connected as well as provides power to USB Device peripherals. See example LV-Baseboard designs for reference components.
22	ACT_nLNK_LED/LAN_LED2	O	3.3V	Active low. Asserts when there is valid Ethernet connection. Deasserts during Ethernet traffic indicating activity. See example LV-Baseboard designs for reference components.
23	USB1_nOC	I	3.3V	Active low. USB OTG over current flag. Indicates to PHY an over current condition exists on the USB OTG port.
24	SPD_LED_n100M_10M/LAN_LED1	O	3.3V	Active low. Asserts to indicate operation speed, either 10 Mb or 100 Mb connection. See example LV-Baseboard designs for reference components.
25	USB1_PWR_nEN	O	3.3V	Active low. USB OTG power enable. Enables power to the external USB power switch. See example LV-Baseboard designs for reference components.
26	VREF_ETHERNET	O	3.3V	AC coupled to GND. Output from the SOM-LV that drives the impedance network and magnetics. Specific to Ethernet PHY requirements. See example LV-Baseboard designs for reference components.
27	USB1_D+	I/O	Variable	USB OTG port 1 I/O data plus signal. Route as differential pair with USB1_D-. Follow USB 2.0 routing guidelines. Route pair with 90 ohms differential impedance.
28	uP_AUX_CLK	O	1.8V	Processor's CLKO output.
29	USB1_D-	I/O	Variable	USB OTG port 1 I/O data minus signal. Route as differential pair with USB1_D+. Follow USB 2.0 routing guidelines. Route pair with 90 ohms differential impedance.
30	PWR_ON	I	2.7V	Active high. Software can use this signal to enter RUN from low power modes. Software is required for correct operation. This signal has a 10K pull-up.
31	DGND	I	GND	Ground. Connect to digital ground.
32	DGND	I	GND	Ground. Connect to digital ground.
33	USB2_D+	I/O	Variable	USB Host port 2 I/O data plus signal. Route as differential pair with USB2_D-. Follow USB 2.0 routing guidelines. Route pair with 90 ohms differential impedance.
34	uP_TIMER_OUT	O	1.8V	Processor GPIO available to user.
35	USB2_D-	I/O	Variable	USB Host port 2 I/O data minus signal. Route as differential pair with USB2_D+. Follow USB 2.0 routing guidelines. Route pair with 90 ohms differential impedance.
36	uP_TIMER_IN	I	1.8V	Processor GPIO available to user.
37	USB2_nOC	I	3.3V	Active low. USB Host over current flag. Indicates to PHY an over current condition exists on the USB Host port.

J1 Pin#	Signal Name	I/O	Voltage	Description
38	LCD_OE_ACD	O	1.8V	Processor GPIO available to user.
39	USB2_PWR_nEN	O	5.0V	Active low. USB Host power enable. Enables power to the external USB power switch. See example LV-Baseboard designs for reference components.
40	uP_D0	I/O	1.8V	Processor Host bus (WEIM bus) data bit 0.
41	RFU	I/O	NA	Reserved for future use. Do not connect.
42	uP_D1	I/O	1.8V	Processor Host bus (WEIM bus) data bit 1.
43	RFU	I/O	NA	Reserved for future use. Do not connect.
44	uP_D2	I/O	1.8V	Processor Host bus (WEIM bus) data bit 2.
45	RFU	I/O	NA	Reserved for future use. Do not connect.
46	uP_D3	I/O	1.8V	Processor Host bus (WEIM bus) data bit 3.
47	RFU	I/O	NA	Reserved for future use. Do not connect.
48	uP_D4	I/O	1.8V	Processor Host bus (WEIM bus) data bit 4.
49	3.3V_nEN	O	2.7V	3.3V external enable pin. Active low, signals to the baseboard the 3.3V supply should be enabled.
50	uP_D5	I/O	1.8V	Processor Host bus (WEIM bus) data bit 5.
51	DGND	I	GND	Ground. Connect to digital ground.
52	DGND	I	GND	Ground. Connect to digital ground.
53	A0 (DGND)	O	1.8V	Processor Host bus (WEIM bus) address bit 0. (see note 1 at the end of this table)
54	uP_D6	I/O	1.8V	Processor Host bus (WEIM bus) data bit 6.
55	A1 (uP_MA0)	O	1.8V	Processor Host bus (WEIM bus) address bit 1. (see note 1)
56	uP_D7	I/O	1.8V	Processor Host bus (WEIM bus) data bit 7.
57	A2 (uP_MA1)	O	1.8V	Processor Host bus (WEIM bus) address bit 2. (see note 1)
58	uP_D8	I/O	1.8V	Processor Host bus (WEIM bus) data bit 8.
59	A3 (uP_MA2)	O	1.8V	Processor Host bus (WEIM bus) address bit 3. (see note 1)
60	uP_D9	I/O	1.8V	Processor Host bus (WEIM bus) data bit 9.
61	A4 (uP_MA3)	O	1.8V	Processor Host bus (WEIM bus) address bit 4. (see note 1)
62	uP_D10	I/O	1.8V	Processor Host bus (WEIM bus) data bit 10.
63	A5 (uP_MA4)	O	1.8V	Processor Host bus (WEIM bus) address bit 5. (see note 1)
64	uP_D11	I/O	1.8V	Processor Host bus (WEIM bus) data bit 11.
65	A6 (uP_MA5)	O	1.8V	Processor Host bus (WEIM bus) address bit 6. (see note 1)
66	uP_D12	I/O	1.8V	Processor Host bus (WEIM bus) data bit 12.
67	A7 (uP_MA6)	O	1.8V	Processor Host bus (WEIM bus) address bit 7. (see note 1)
68	uP_D13	I/O	1.8V	Processor Host bus (WEIM bus) data bit 13.
69	A8 (uP_MA7)	O	1.8V	Processor Host bus (WEIM bus) address bit 8. (see note 1)
70	uP_D14	I/O	1.8V	Processor Host bus (WEIM bus) data bit 14.
71	DGND	I	GND	Ground. Connect to digital ground.
72	DGND	I	GND	Ground. Connect to digital ground.
73	A9 (uP_MA8)	O	1.8V	Processor Host bus (WEIM bus) address bit 9. (see note 1)
74	uP_D15	I/O	1.8V	Processor Host bus (WEIM bus) data bit 15.
75	A10 (uP_MA9)	O	1.8V	Processor Host bus (WEIM bus) address bit 10. (see note 1)
76	RFU	I/O	NA	Reserved for future use. Do not connect.
77	A11 (uP_MA10)	O	1.8V	Processor Host bus (WEIM bus) address bit 11. (see note 1)
78	RFU	I/O	NA	Reserved for future use. Do not connect.

i.MX27 SOM-LV Hardware Specification

J1 Pin#	Signal Name	I/O	Voltage	Description
79	A12 (uP_MA11)	O	1.8V	Processor Host bus (WEIM bus) address bit 12. (see note 1)
80	RFU	I/O	NA	Reserved for future use. Do not connect.
81	A13 (uP_MA12)	O	1.8V	Processor Host bus (WEIM bus) address bit 13. (see note 1)
82	RFU	I/O	NA	Reserved for future use. Do not connect.
83	A14 (uP_A13)	O	1.8V	Processor Host bus (WEIM bus) address bit 14. (see note 1)
84	RFU	I/O	NA	Reserved for future use. Do not connect.
85	A15 (uP_A14)	O	1.8V	Processor Host bus (WEIM bus) address bit 15. (see note 1)
86	RFU	I/O	NA	Reserved for future use. Do not connect.
87	A16 (uP_A15)	O	1.8V	Processor Host bus (WEIM bus) address bit 16. (see note 1)
88	RFU	I/O	NA	Reserved for future use. Do not connect.
89	A17 (uP_A16)	O	1.8V	Processor Host bus (WEIM bus) address bit 17. (see note 1)
90	RFU	I/O	NA	Reserved for future use. Do not connect.
91	DGND	I	GND	Ground. Connect to digital ground.
92	DGND	I	GND	Ground. Connect to digital ground.
93	A18 (uP_A17)	O	1.8V	Processor Host bus (WEIM bus) address bit 18. (see note 1)
94	RFU	I/O	NA	Reserved for future use. Do not connect.
95	A19 (uP_A18)	O	1.8V	Processor Host bus (WEIM bus) address bit 19. (see note 1)
96	RFU	I/O	NA	Reserved for future use. Do not connect.
97	A20 (uP_A19)	O	1.8V	Processor Host bus (WEIM bus) address bit 20. (see note 1)
98	RFU	I/O	NA	Reserved for future use. Do not connect.
99	A21 (uP_A20)	O	1.8V	Processor Host bus (WEIM bus) address bit 21. (see note 1)
100	RFU	I/O	NA	Reserved for future use. Do not connect.
101	A22 (uP_A21)	O	1.8V	Processor Host bus (WEIM bus) address bit 22. (see note 1)
102	D28 (RFU)	I/O	NA	Reserved for future use. Do not connect.
103	A23 (uP_A22)	O	1.8V	Processor Host bus (WEIM bus) address bit 23. (see note 1)
104	RFU	I/O	NA	Reserved for future use. Do not connect.
105	A24 (uP_A23)	O	1.8V	Processor Host bus (WEIM bus) address bit 24. (see note 1)
106	RFU	I/O	NA	Reserved for future use. Do not connect.
107	A25 (uP_A24)	O	1.8V	Processor Host bus (WEIM bus) address bit 25. (see note 1)
108	RFU	I/O	NA	Reserved for future use. Do not connect.
109	uP_nWAIT	I	1.8V	Active low. Processor Host bus (WEIM bus) ECB signal. Used to extend bus transactions beyond programmed wait states. The external device signals completion of the cycle by deasserting the uP_nWAIT signal. This signal has a 2.2K pull-up.
110	VREF_DATA_BUS	O	1.8V	Voltage reference output created on SOM-LV for the data bus.
111	DGND	I	GND	Ground. Connect to digital ground.
112	DGND	I	GND	Ground. Connect to digital ground.
113	uP_nIRQD	I	1.8V	Active low. Software can use as a hardware interrupt. This signal is pulled high with a 10K resistor.
114	SLOW_nCS	O	1.8V	Active low. Memory mode only CompactFlash chip enable. (see note 2)

J1 Pin#	Signal Name	I/O	Voltage	Description
115	uP_nIRQC	I	1.8V	Active low. Software can use as a hardware interrupt. This signal is pulled high with a 10K resistor.
116	CF_nWE (uP_nEB0)	O	1.8V	Active low. Memory mode CompactFlash write enable signal. Indicates the current SOM-LV bus transaction is writing data to the CompactFlash card. (see note 2)
117	uP_nIRQB	I	1.8V	Active low. Software can use as a hardware interrupt. This signal is pulled high with a 10K resistor.
118	CF_nOE (uP_nOE)	O	1.8V	Active low. Memory mode CompactFlash read enable signal. Indicates the current SOM-LV bus transaction is reading data from the CompactFlash card. (see note 2)
119	uP_nIRQA	I	1.8V	Active low. Software can use as a hardware interrupt. This signal is pulled high with a 10K resistor.
120	nCHRDY	I	3.3V	Active low. CompactFlash nCHRDY signal used to extend bus cycle to memory mode CompactFlash cards. This signal has a 470K pull-up to 3.3V. Note: baseboard should provide a pull up on nCHRDY to the voltage of the CompactFlash card being used. (see note 2)
121	BUFF_nOE_DATA	O	1.8V	Active low. When this signal is low, external devices can drive data onto the WEIM bus.
122	uP_UARTC_CTS	I	1.8V	Clear To Send signal for CSPI3 UART.
123	BUFF_DIR_DATA	O	1.8V	When low, external buffers should drive data from external devices towards the SOM-LV. (SOM-LV is reading) When high, external buffers should drive data from the SOM-LV towards external devices. (SOM-LV is writing).
124	uP_UARTC_RTS	O	1.8V	Ready To Send signal for CSPI3 UART.
125	uP_nOE	O	1.8V	Active low. Used to indicate processor is reading from external devices.
126	uP_UARTC_RX	I	1.8V	Serial Data Receive signal for CSPI3 UART.
127	uP_RnW	O	1.8V	Low indicates processor is writing. High indicates processor is reading.
128	uP_UARTC_TX	O	1.8V	Serial Data Transmit signal for CSPI3 UART.
129	DGND	I	GND	Ground. Connect to digital ground.
130	DGND	I	GND	Ground. Connect to digital ground.
131	uP_BUS_CLK	O	1.8V	Processor WEIM bus clock. Frequency varies based on software setup.
132	uP_UARTB_RX	I	1.8V	Serial Data Receive signal for UART2.
133	RFU	I/O	NA	Reserved for future use. Do not connect.
134	uP_UARTB_TX	O	1.8V	Serial Data Transmit signal for UART2.
135	RFU	I/O	NA	Reserved for future use. Do not connect.
136	uP_UARTB_CTS	I	1.8V	Clear To Send signal for UART2.
137	uP_nBLE0 (uP_nEB0)	O	1.8V	Processor WEIM bus Byte Lane Enable 0 bits [7:0]
138	uP_UARTB_RTS	O	1.8V	Ready To Send signal for UART2.
139	uP_nBLE1 (uP_nEB1)	O	1.8V	Processor WEIM bus Byte Lane Enable 1 bits [15:8]
140	RFU	I/O	NA	Reserved for future use. Do not connect.
141	uP_nCS_B_EXT	O	1.8V	External Chip select available for customer use.
142	uP_GPIO3	I/O	1.8V	Processor GPIO available to user.
143	uP_nCS_A_EXT	O	1.8V	External Chip select available for customer use.
144	VREF_I2C1	O	1.8V	Reference voltage output for I2C DATA and CLK signals
145	SLOW_nCS	O	1.8V	External Chip select available for customer use.

i.MX27 SOM-LV Hardware Specification

J1 Pin#	Signal Name	I/O	Voltage	Description
146	I2C1_DATA	I/O	1.8V	I2C channel 1 data signal. This signal has a pull-up to the reference voltage onboard.
147	FAST_nCS	O	1.8V	External Chip select available for customer use.
148	I2C1_CLK	I/O	1.8V	I2C channel 1 clock signal. This signal has a pull-up to the reference voltage onboard.
149	DGND	I	GND	Ground. Connect to digital ground.
150	DGND	I	GND	Ground. Connect to digital ground.
151	LCD_SPL	O	1.8V	LCD Start Pulse Left signal.
152	VREF_UARTA	O	1.8V	Voltage reference output for UART1 signals.
153	LCD_DON	O	1.8V	LCD Data On signal.
154	uP_UARTA_DSR	I	1.8V	Data Set Ready signal for UART1.
155	LCD_CLS	O	1.8V	LCD CLS signal.
156	uP_UARTA_DTR	O	1.8V	Data Terminal Ready signal for UART1.
157	RFU	I/O	NA	Reserved for future use. Do not connect.
158	uP_UARTA_RX	I	1.8V	Data Receive signal for UART1.
159	RFU	I/O	NA	Reserved for future use. Do not connect.
160	uP_UARTA_TX	O	1.8V	Data Transmit signal for UART1.
161	LCD_PANEL_PWR	O	1.8V	LCD Panel Power signal.
162	uP_UARTA_CTS	I	1.8V	Clear To Send signal for UART1.
163	LCD_BACKLIGHT_PWR	O	1.8V	LCD Backlight Power signal. Active High.
164	uP_UARTA_RTS	O	1.8V	Ready To Send signal for UART1.
165	LCD_HSYNC	O	1.8V	LCD Horizontal Sync signal.
166	RFU	I/O	NA	Reserved for future use. Do not connect.
167	LCD_VSYNC	O	1.8V	LCD Vertical Sync Signal.
168	PWM0	O	1.8V	PWM output 0.
169	DGND	I	GND	Ground. Connect to digital ground.
170	DGND	I	GND	Ground. Connect to digital ground.
171	LCD_DCLK	O	1.8V	LCD Data Clock output.
172	3.3V_uP_BATT	I	3.3V	External input that supplies power to the onboard power management controller and RTC interface. This signal should be powered by a coin-cell type battery or an always on power source.
173	LCD_REV	O	1.8V	LCD Reverse signal.
174	5V	I	5V	5V power input. Used by power management controller to charge external MAIN_BATTERY supply or can power the SOM-LV if the MAIN_BATTERY input is not used. Note: the default population of the module does not include devices to support 5V power input or MAIN_BATTERY charging. If these options are desired, please contact sales@logicpd.com for information on obtaining a custom assembly.
175	MDISP (LCD_PSAVE/MDISP)	O	1.8V	LCD MDISP signal.
176	5V	I	5V	5V power input. Used by power management controller to charge external MAIN_BATTERY supply or can power the SOM-LV if the MAIN_BATTERY input is not used. Note: the default population of the module does not include devices to support 5V power input or MAIN_BATTERY charging. If these options are desired, please contact sales@logicpd.com for information on obtaining a custom assembly.
177	PSAVE (LCD_PSAVE/MDISP)	O	1.8V	LCD Power Save signal.

J1 Pin#	Signal Name	I/O	Voltage	Description
				5V power input. Used by power management controller to charge external MAIN_BATTERY supply or can power the SOM-LV if the MAIN_BATTERY input is not used. Note: the default population of the module does not include devices to support 5V power input or MAIN_BATTERY charging. If these options are desired, please contact sales@logicpd.com for information on obtaining a custom assembly.
178	5V	I	5V	
179	RFU	I/O	NA	Reserved for future use. Do not connect.
180	3.3V_IN	I	3.3V	External 3.3V power input. This signal supplies power to 3.3V components onboard.
181	RFU	I/O	NA	Reserved for future use. Do not connect.
182	3.3V_IN	I	3.3V	External 3.3V power input. This signal supplies power to 3.3V components onboard.
183	VREF_LCD	O	1.8V	Voltage reference output for the LCD interface.
184	3.3V_IN	I	3.3V	External 3.3V power input. This signal supplies power to 3.3V components onboard.
185	R1 (LD13)	O	1.8V	LCD R1 data bit when operating in 16 bpp 5:6:5 color mode.
186	TOUCH_LEFT	I	max 2.7V	Touch panel LEFT input signal.
187	R2 (LD14)	O	1.8V	LCD R2 data bit when operating in 16 bpp 5:6:5 color mode.
188	TOUCH_RIGHT	I	max 2.7V	Touch panel RIGHT input signal.
189	DGND	I	GND	Ground. Connect to digital ground.
190	DGND	I	GND	Ground. Connect to digital ground.
191	R3 (LD15)	O	1.8V	LCD R3 data bit when operating in 16 bpp 5:6:5 color mode.
192	TOUCH_BOTTOM	I	max 2.7V	Touch panel BOTTOM input signal.
193	R4 (LD16)	O	1.8V	LCD R4 data bit when operating in 16 bpp 5:6:5 color mode.
194	TOUCH_TOP	I	max 2.7V	Touch panel TOP input signal.
195	R5 (LD17)	O	1.8V	LCD R5 data bit when operating in 16 bpp 5:6:5 color mode.
196	A/D4	I	max 2.7V	Analog to digital converter input 4.
197	G0 (LD6)	O	1.8V	LCD G0 data bit when operating in 16 bpp 5:6:5 color mode.
198	A/D3	I	max 2.7V	Analog to digital converter input 3.
199	G1 (LD7)	O	1.8V	LCD G1 data bit when operating in 16 bpp 5:6:5 color mode.
200	A/D2	I	max 2.7V	Analog to digital converter input 2.
201	G2 (LD8)	O	1.8V	LCD G2 data bit when operating in 16 bpp 5:6:5 color mode.
202	A/D1	I	max 2.7V	Analog to digital converter input 1.
203	G3 (LD9)	O	1.8V	LCD G3 data bit when operating in 16 bpp 5:6:5 color mode.
204	MAIN_BATTERY	I	max 4.6V	External power source input. This signal should be driven directly by a single cell lithium-ion battery or a fixed 3.3V regulated power source.
205	G4 (LD10)	O	1.8V	LCD G4 data bit when operating in 16 bpp 5:6:5 color mode.
206	MAIN_BATTERY	I	max 4.6V	External power source input. This signal should be driven directly by a single cell lithium-ion battery or a fixed 3.3V regulated power source.
207	G5 (LD11)	O	1.8V	LCD G5 data bit when operating in 16 bpp 5:6:5 color mode.
208	MAIN_BATTERY	I	max 4.6V	External power source input. This signal should be driven directly by a single cell lithium-ion battery or a fixed 3.3V regulated power source.

J1 Pin#	Signal Name	I/O	Voltage	Description
209	DGND	I	GND	Ground. Connect to digital ground.
210	DGND	I	GND	Ground. Connect to digital ground.
211	B1 (LD1)	O	1.8V	LCD B1 data bit when operating in 16 bpp 5:6:5 color mode.
212	MAIN_BATTERY	I	max 4.6V	External power source input. This signal should be driven directly by a single cell lithium-ion battery or a fixed 3.3V regulated power source.
213	B2 (LD2)	O	1.8V	LCD B2 data bit when operating in 16 bpp 5:6:5 color mode.
214	MAIN_BATTERY	I	max 4.6V	External power source input. This signal should be driven directly by a single cell lithium-ion battery or a fixed 3.3V regulated power source.
215	B3 (LD3)	O	1.8V	LCD B3 data bit when operating in 16 bpp 5:6:5 color mode.
216	uP_GPIO_1	I/O	1.8V	Processor GPIO available to user.
217	B4 (LD4)	O	1.8V	LCD B4 data bit when operating in 16 bpp 5:6:5 color mode.
218	uP_GPIO_0	I/O	1.8V	Processor GPIO available to user.
219	B5 (LD5)	O	1.8V	LCD B5 data bit when operating in 16 bpp 5:6:5 color mode.
220	uP_CSPI1_SS1	O	1.8V	SPI interface chip select 1 output.
221	ONE_WIRE (uP_RTCK/1WIRE)	I/O	1.8V	Bi-directional battery management ONEWIRE interface.
222	RFU	I/O	NA	Reserved for future use. Do not connect.
223	uP_SW_nRESET	I	1.8V	Active low. Input to CPU. Software can setup GPIO as an interrupt. Signal has a 10K pull-up to 2.7V.
224	uP_CSPI1_MISO	I	1.8V	SPI interface receive input.
225	RESET_nOUT (PMIC_nRESET)	O	1.8V	Active low. Reset output from the power management controller that drives all onboard reset inputs. This signal should be used to drive reset inputs on external chips that require similar timing to the onboard devices. The RESET_nOUT signal has an onboard 4.7K pull-up to 1.8V_NVDD1 rail.
226	uP_CSPI1_MOSI	O	1.8V	SPI interface transmit output.
227	MSTR_nRST	I	1.8V	Active low. External reset input to the SOM-LV. This signal should be used to reset all devices on the SOM-LV including the CPU. The MSTR_nRST signal has an onboard 4.7K pull-up to 1.8V_NVDD1 rail.
228	uP_CSPI1_SCLK	O	1.8V	SPI Serial clock signal.
229	DGND	I	GND	Ground. Connect to digital ground.
230	DGND	I	GND	Ground. Connect to digital ground.
231	RFU	I/O	NA	Reserved for future use. Do not connect.
232	RFU	I/O	NA	Reserved for future use. Do not connect.
233	RFU	I/O	NA	Reserved for future use. Do not connect.
234	RFU	I/O	NA	Reserved for future use. Do not connect.
235	RFU	I/O	NA	Reserved for future use. Do not connect.
236	RFU	I/O	NA	Reserved for future use. Do not connect.
237	RFU	I/O	NA	Reserved for future use. Do not connect.
238	RFU	I/O	NA	Reserved for future use. Do not connect.
239	RFU	I/O	NA	Reserved for future use. Do not connect.
240	RFU	I/O	NA	Reserved for future use. Do not connect.

Note 1: The signals in parentheses are the net names specific to i.MX27 SOM-LV; the non-parenthetical names are the signal names that are general to the form factor module.

Note 2: CF_nCE, CF_nOE, and CF_nWE can be used as control signals with WEIM Address and Data to create an external memory mode only CompactFlash interface. These signals are not

used for the standard CompactFlash/PC Card interface that is available on J2, nor are they used for the J4 CompactFlash socket available on the LV-Baseboard.

5.2 J2 Connector 240-Pin Descriptions

J2 Pin#	Signal Name	I/O	Voltage	Description
1	RFU	I/O	NA	Reserved for future use. Do not connect.
2	RFU	I/O	NA	Reserved for future use. Do not connect.
3	RFU	I/O	NA	Reserved for future use. Do not connect.
4	RFU	I/O	NA	Reserved for future use. Do not connect.
5	RFU	I/O	NA	Reserved for future use. Do not connect.
6	RFU	I/O	NA	Reserved for future use. Do not connect.
7	RFU	I/O	NA	Reserved for future use. Do not connect.
8	RFU	I/O	NA	Reserved for future use. Do not connect.
9	RFU	I/O	NA	Reserved for future use. Do not connect.
10	RFU	I/O	NA	Reserved for future use. Do not connect.
11	DGND	I	GND	Ground. Connect to digital ground.
12	DGND	I	GND	Ground. Connect to digital ground.
13	PCC_POWER_nEN	O	1.8V	Active low. Turns on power to CompactFlash/PC Card interface.
14	PCC_nOE (uP_nLBA)	O	1.8V	Active low. CompactFlash/PC Card per transaction bus buffer Output Enable signal.
15	PCC_PCMCIA_nEN	O	1.8V	Active low. Enables CompactFlash address and control signals.
16	uP_PCC_RDYA/ATA_CS0	I	1.8V	Active high. CompactFlash/PC Card Ready signal.
17	MFP (RFU)	I/O	NA	Reserved for future use. Do not connect.
18	uP_PCC_nWAIT/ATA_CS1	I	1.8V	Active low. CompactFlash/PC Card Wait signal.
19	MFP (RFU)	I/O	NA	Reserved for future use. Do not connect.
20	uP_PCC_BVD2_DMACK	I	1.8V	CompactFlash/PC Card Battery Voltage Detect 2 input.
21	uP_ATA_D15	I/O	1.8V	ATA interface Data bit 15. This interface is multiplexed with other onboard interfaces.
22	uP_PCC_BVD1/ATA_DMARQ	I	1.8V	CompactFlash/PC Card Battery Voltage Detect 1 input.
23	uP_ATA_D14	I/O	1.8V	ATA interface Data bit 14. This interface is multiplexed with other onboard interfaces.
24	uP_PCC_CD2/ATA_DIOW	I	1.8V	CompactFlash/ PC Card Detect 2 input.
25	uP_ATA_D13	I/O	1.8V	ATA interface Data bit 13. This interface is multiplexed with other onboard interfaces.
26	uP_PCC_CD1/ATA_DIOR	I	1.8V	CompactFlash/ PC Card Detect 1 input.
27	uP_ATA_D12	I/O	1.8V	ATA interface Data bit 12. This interface is multiplexed with other onboard interfaces.
28	uP_PCC_VS1/ATA_DA1	I	1.8V	CompactFlash/ PC Card Voltage Sense 1 input.
29	uP_ATA_D11	I/O	1.8V	ATA interface Data bit 11. This interface is multiplexed with other onboard interfaces.
30	uP_PCC_VS2/ATA_DA0	I	1.8V	CompactFlash/PC Card Voltage Sense 2 input.
31	DGND	I	GND	Ground. Connect to digital ground.
32	DGND	I	GND	Ground. Connect to digital ground.
33	uP_ATA_D10	I/O	1.8V	ATA interface Data bit 10. This interface is multiplexed with other onboard interfaces.
34	PCC_RESET (uP_PCC_RESET/ATA_nRESET)	I	1.8V	CompactFlash/PC Card Reset output.
35	uP_ATA_D9	I/O	1.8V	ATA interface Data bit 9. This interface is multiplexed with other onboard interfaces.
36	PCC_nDRV (uP_PC_POE/ATA_BUFFER_EN)	O	1.8V	CompactFlash/PC Card buffer Drive output.
37	uP_ATA_D8	I/O	1.8V	ATA interface Data bit 8. This interface is multiplexed with other onboard interfaces.

J2 Pin#	Signal Name	I/O	Voltage	Description
38	PCC_nIOWR (uP_nOE)	O	1.8V	Active low. CompactFlash/PC Card I/O Write output.
39	uP_ATA_D7	I/O	1.8V	ATA interface Data bit 7. This interface is multiplexed with other onboard interfaces.
40	PCC_nWE (uP_RnW)	O	1.8V	Active low. CompactFlash/PC Card Write Enable output.
41	uP_ATA_D6	I/O	1.8V	ATA interface Data bit 6. This interface is multiplexed with other onboard interfaces.
42	PCC_nIORD (uP_nEB1)	O	1.8V	Active low. CompactFlash/PC Card I/O Read output.
43	uP_ATA_D5	I/O	1.8V	ATA interface Data bit 5. This interface is multiplexed with other onboard interfaces.
44	PCC_REG (uP_nEB0)	O	1.8V	CompactFlash/PC Card Reg access output.
45	uP_ATA_D4	I/O	1.8V	ATA interface Data bit 4. This interface is multiplexed with other onboard interfaces.
46	uP_PCC_nIOIS16/ATA_INTRQ	I	1.8V	CompactFlash/PC Card nIOIS16 input.
47	uP_ATA_D3	I/O	1.8V	ATA interface Data bit 3. This interface is multiplexed with other onboard interfaces.
48	PCC_nCE1A (uP_MSDBA1)	O	1.8V	Active low. CompactFlash/PC Card Chip Enable 1A.
49	uP_ATA_D2	I/O	1.8V	ATA interface Data bit 2. This interface is multiplexed with other onboard interfaces.
50	PCC_nCE2A (uP_MSDBA0)	O	1.8V	Active low. CompactFlash/PC Card Chip Enable 2A.
51	DGND	I	GND	Ground. Connect to digital ground.
52	DGND	I	GND	Ground. Connect to digital ground.
53	uP_ATA_D1	I/O	1.8V	ATA interface Data bit 1. This interface is multiplexed with other onboard interfaces.
54	VREF_PCMCIA	O	1.8V	CompactFlash/PC Card Voltage reference output.
55	uP_ATA_D0	I/O	1.8V	ATA interface Data bit 0. This interface is multiplexed with other onboard interfaces.
56	uP_A25	O	1.8V	Processor WEIM bus Address bit 26 output.
57	IORDY (uP_PC_RnW/ATA_IORDY)	O	1.8V	ATA interface IORDY output. This interface is multiplexed with other onboard interfaces.
58	RFU	I/O	NA	Reserved for future use. Do not connect.
59	ATA_RESET (uP_PCC_RESET/ATA_nRESET)	I	1.8V	ATA interface Reset output. This interface is multiplexed with other onboard interfaces.
60	RFU	I/O	NA	Reserved for future use. Do not connect.
61	ATA_DMACK (uP_PCC_BVD2_DMACK)	I	1.8V	ATA interface DMA Acknowledge output. This interface is multiplexed with other onboard interfaces.
62	RFU	I/O	NA	Reserved for future use. Do not connect.
63	ATA_DIOW (uP_PCC_CD2/ATA_DIOW)	I	1.8V	ATA interface Data I/O Write output. This interface is multiplexed with other onboard interfaces.
64	RFU	I/O	NA	Reserved for future use. Do not connect.
65	ATA_DIOR (uP_PCC_CD1/ATA_DIOR)	I	1.8V	ATA interface Data I/O Read output. This interface is multiplexed with other onboard interfaces.
66	RFU	I/O	NA	Reserved for future use. Do not connect.
67	ATA_CS1 (uP_PCC_nWAIT/ATA_CS1)	I	1.8V	ATA interface Chip Select 1 output. This interface is multiplexed with other onboard interfaces.
68	RFU	I/O	NA	Reserved for future use. Do not connect.
69	ATA_CS0 (uP_PCC_RDYA/ATA_CS0)	I	NVDD3	ATA interface Chip Select 0 output. This interface is multiplexed with other onboard interfaces.
70	RFU	I/O	NA	Reserved for future use. Do not connect.
71	DGND	I	GND	Ground. Connect to digital ground.

J2 Pin#	Signal Name	I/O	Voltage	Description
72	DGND	I	GND	Ground. Connect to digital ground.
73	RFU	I/O	NA	Reserved for future use. Do not connect.
74	RFU	I/O	NA	Reserved for future use. Do not connect.
75	RFU	I/O	NA	Reserved for future use. Do not connect.
76	RFU	I/O	NA	Reserved for future use. Do not connect.
77	RFU	I/O	NA	Reserved for future use. Do not connect.
78	RFU	I/O	NA	Reserved for future use. Do not connect.
79	RFU	I/O	NA	Reserved for future use. Do not connect.
80	VREF_MMC/SD2 (NVDD15)	O	NVDD15	MMC/SD2 interface voltage reference output.
81	CDCOUT	O	2.7V	MC13783 CDCOUT signal.
82	SD2_DATA3	I/O	NVDD15	MMC/SD2 Data 3 signal.
83	uP_CSPI1_RDY	I	1.8V	CSPI1 Ready signal.
84	SD2_DATA2	I/O	NVDD15	MMC/SD2 Data 2 signal.
85	RFU	I/O	NA	Reserved for future use. Do not connect.
86	SD2_DATA1	I/O	NVDD15	MMC/SD2 Data 1 signal.
87	RFU	I/O	NA	Reserved for future use. Do not connect.
88	SD2_DATA0	I/O	NVDD15	MMC/SD2 Data 0 signal.
89	RFU	I/O	NA	Reserved for future use. Do not connect.
90	SD2_CMD	I/O	NVDD15	MMC/SD2 Command signal.
91	DGND	I	GND	Ground. Connect to digital ground.
92	DGND	I	GND	Ground. Connect to digital ground.
93	PC_PWRON/ATA_DA2	I	1.8V	ATA_DA2
94	SD2_CLK	I/O	NVDD15	MMC/SD2 Clock signal.
95	uP_PCC_VS1/ATA_DA1	I	1.8V	ATA_DA1
96	VREF_I2C2	O	1.8V	I2C channel 2 voltage reference output.
97	uP_PCC_VS2/ATA_DA0	I	1.8V	ATA_DA0
98	I2C2_CLK	I/O	1.8V	I2C channel 2 Clock signal.
99	uP_PCC_BVD1/ATA_DMARQ	I	1.8V	ATA_DMARQ
100	I2C2_DATA	I/O	1.8V	I2C channel 2 Data signal.
101	KEY_COL3	I/O	1.8V	Keypad Column 3 signal.
102	RFU	I/O	NA	Reserved for future use. Do not connect.
103	KEY_COL2	I/O	1.8V	Keypad Column 2 signal.
104	RFU	I/O	NA	Reserved for future use. Do not connect.
105	KEY_COL1	I/O	1.8V	Keypad Column 1 signal.
106	RFU	I/O	NA	Reserved for future use. Do not connect.
107	KEY_COLO	I/O	1.8V	Keypad Column 0 signal.
108	uP_TMS	I	1.8V	CPU JTAG Test Mode Signal. This signal has a 4.7k ohm pull up.
109	uP_PC_POE/ATA_BUFFER_EN	O	1.8V	ATA_BUFFER_EN
110	uP_TCK	I	1.8V	CPU JTAG Test Clock input signal.
111	DGND	I	GND	Ground. Connect to digital ground.
112	DGND	I	GND	Ground. Connect to digital ground.
113	uP_PCC_nIOIS16/ATA_INTRQ	I	1.8V	ATA_INTRQ
114	uP_TDO	O	1.8V	CPU JTAG Test Data Output from the CPU to the JTAG device.
115	RFU	I/O	NA	Reserved for future use. Do not connect.
116	uP_nTRST	I	1.8V	CPU JTAG Test Reset input. This signal has a 4.7k ohm pull up.
117	RFU	I/O	NA	Reserved for future use. Do not connect.
118	uP_TDI	I	1.8V	CPU JTAG Test Data Input to the CPU from the JTAG device. This signal has a 4.7k ohm pull-up.
119	KEY_ROW3	I/O	1.8V	Keypad Row 3 signal.
120	uP_RTCK/1WIRE	O	1.8V	CPU JTAG Return Test Clock signal.
121	KEY_ROW2	I/O	1.8V	Keypad Row 2 signal.
122	VREF_JTAG	O	NVDD8	CPU JTAG reference voltage output.
123	KEY_ROW1	I/O	1.8V	Keypad Row 1 signal.

J2 Pin#	Signal Name	I/O	Voltage	Description
124	RFU	I/O	NA	Reserved for future use. Do not connect.
125	KEY_ROW0	I/O	1.8V	Keypad Row 0 signal.
126	RFU	I/O	NA	Reserved for future use. Do not connect.
127	CSI_HSYNC	I/O	1.8V	Camera Sensor Interface Horizontal Sync signal.
128	RFU	I/O	NA	Reserved for future use. Do not connect.
129	DGND	I	GND	Ground. Connect to digital ground.
130	DGND	I	GND	Ground. Connect to digital ground.
131	CSI_VSYNC	I/O	1.8V	Camera Sensor Interface Vertical Sync signal.
132	RFU	I/O	NA	Reserved for future use. Do not connect.
133	CSI_D0	I/O	1.8V	Camera Sensor Interface Data bit 0.
134	RFU	I/O	NA	Reserved for future use. Do not connect.
135	CSI_D1	I/O	1.8V	Camera Sensor Interface Data bit 1.
136	RFU	I/O	NA	Reserved for future use. Do not connect.
137	CSI_D2	I/O	1.8V	Camera Sensor Interface Data bit 2.
138	VREF_MMC/SD1	O	NVDD8	MMC/SD1 interface voltage reference output.
139	CSI_D3	I/O	1.8V	Camera Sensor Interface Data bit 3.
140	RFU	I/O	NA	Reserved for future use. Do not connect.
141	CSI_D4	I/O	1.8V	Camera Sensor Interface Data bit 4.
142	RFU	I/O	NA	Reserved for future use. Do not connect.
143	CSI_D5	I/O	1.8V	Camera Sensor Interface Data bit 5.
144	RFU	I/O	NA	Reserved for future use. Do not connect.
145	CSI_D6	I/O	1.8V	Camera Sensor Interface Data bit 6.
146	RFU	I/O	NA	Reserved for future use. Do not connect.
147	CSI_D7	I/O	1.8V	Camera Sensor Interface Data bit 7.
148	RFU	I/O	NA	Reserved for future use. Do not connect.
149	DGND	I	GND	Ground. Connect to digital ground.
150	DGND	I	GND	Ground. Connect to digital ground.
151	RFU	I/O	NA	Reserved for future use. Do not connect.
152	PCC_POWER_nEN	O	1.8V	When asserted low this signal should turn power on to CompactFlash/ CF Card slot.
153	RFU	I/O	NA	Reserved for future use. Do not connect.
154	RFU	I/O	NA	Reserved for future use. Do not connect.
155	RFU	I/O	NA	Reserved for future use. Do not connect.
156	LCD_CONTRAST	O	1.8V	LCD Contrast signal.
157	RFU	I/O	NA	Reserved for future use. Do not connect.
158	RFU	I/O	NA	Reserved for future use. Do not connect.
159	RFU	I/O	NA	Reserved for future use. Do not connect.
160	RFU	I/O	NA	Reserved for future use. Do not connect.
161	RFU	I/O	NA	Reserved for future use. Do not connect.
162	RFU	I/O	NA	Reserved for future use. Do not connect.
163	RFU	I/O	NA	Reserved for future use. Do not connect.
164	RFU	I/O	NA	Reserved for future use. Do not connect.
165	RFU	I/O	NA	Reserved for future use. Do not connect.
166	RFU	I/O	NA	Reserved for future use. Do not connect.
167	CSI_MCLK	I/O	1.8V	Camera Sensor Interface Master Clock signal.
168	EXT_BOOT_nSELECT	I	1.8V	Boot select signal (0 = external boot device, 1 = onboard flash). This is accomplished by onboard logic: if signal EXT_BOOT_nSELECT is high, then FLASH_nCS = uP_nCS0; if signal EXT_BOOT_nSELECT is low, then BOOT_nCS = uP_nCS0. This defaults to the onboard flash if left unconnected (pulled to 1.8V through a 10K resistor).
169	DGND	I	GND	Ground. Connect to digital ground.
170	DGND	I	GND	Ground. Connect to digital ground.
171	CSI_PCLK	I/O	1.8V	Camera Sensor Interface Pixel Clock signal.

J2 Pin#	Signal Name	I/O	Voltage	Description
172	BOOT_nCS	O	1.8V	Active Low. This signal is the chip select for boot ROM in area 0 when EXT_BOOT_nSELECT is low. When EXT_BOOT_nSELECT is high, this signal is inactive. See memory map for addressing details.
173	VREF_CSI	O	1.8V	Camera Sensor Interface reference voltage output.
174	RFU	I/O	NA	Reserved for future use. Do not connect.
175	LEDB3	O	max 5.5V	LED Drive Blue bit 3.
176	RFU	I/O	NA	Reserved for future use. Do not connect.
177	LEDG3	O	max 5.5V	LED Drive Green bit 3.
178	RFU	I/O	NA	Reserved for future use. Do not connect.
179	LEDR3	O	max 5.5V	LED Drive Red bit 3.
180	RFU	I/O	NA	Reserved for future use. Do not connect.
181	LEDB2	O	max 5.5V	LED Drive Blue bit 2.
182	LD0	O	1.8V	LCD B0 data bit.
183	LEDG2	O	max 5.5V	LED Drive Green bit 2.
184	RFU	I/O	NA	Reserved for future use. Do not connect.
185	LEDR2	O	max 5.5V	LED Drive Red bit 2.
186	RFU	I/O	NA	Reserved for future use. Do not connect.
187	LEDB1	O	max 5.5V	LED Drive Blue bit 1.
188	LD12	O	1.8V	RLCD R0 data bit.
189	DGND	I	GND	Ground. Connect to digital ground.
190	DGND	I	GND	Ground. Connect to digital ground.
191	LEDG1	O	max 5.5V	LED Drive Green bit 1.
192	HSPGF	O	2.7V	See MC13783 data sheet for more information.
193	LEDR1	O	max 5.5V	LED Drive Red bit 1.
194	HSPGS	O	2.7V	See MC13783 data sheet for more information.
195	LEDKP	O	max 5.5V	LED Key Press signal.
196	LSPL	O	2.7V	See MC13783 data sheet for more information.
197	LEDAD2	O	max 5.5V	LED AD2 signal.
198	SPM	O	2.7V	See MC13783 data sheet for more information.
199	LEDAD1	O	max 5.5V	LED AD1 signal.
200	SPP	O	2.7V	See MC13783 data sheet for more information.
201	LEDMD4	O	max 5.5V	LED MD4 signal.
202	LSPM	O	2.7V	See MC13783 data sheet for more information.
203	LEDMD3	O	max 5.5V	LED MD3 signal.
204	LSPP	O	2.7V	See MC13783 data sheet for more information.
205	LEDMD2	O	max 5.5V	LED MD2 signal.
206	A/D6	I	max 2.7V	Analog to Digital Converter 6 input.
207	LEDMD1	O	max 5.5V	LED MD1 signal.
208	A/D5	I	max 2.7V	Analog to Digital Converter 5 input.
209	DGND	I	GND	Ground. Connect to digital ground.
210	DGND	I	GND	Ground. Connect to digital ground.
211	HSLDET	I	2.7V	Head Set Left detect signal.
212	MIC_IN	I	2.7V	Microphone input.
213	PC_PWRON/ATA_DA2	O	NVDD3	PC Card power applied input.
214	MIC_INR	I	2.7V	Right side microphone input.
215	ATLAS_GPO3	O	2.7V	MC13783 general purpose output.
216	MIC_INL	I	2.7V	Left side microphone input.
217	ATLAS_GPO2	O	2.7V	MC13783 general purpose output.
218	HP_OUTL	O	2.7V	Head Phone Out Left channel.
219	ATLAS_GPO1	O	2.7V	MC13783 general purpose output.
220	HP_OUTR	O	2.7V	Head Phone Out Right channel.
221	I2S/AC97_CLK (uP_SCK1)	O	1.8V	I2S Serial Clock signal.
222	CODEC_INL	I	2.7V	CODEC Left channel Line In.
223	I2S/AC97_FRAME (uP_SFS1)	O	1.8V	I2S Framing signal.

J2 Pin#	Signal Name	I/O	Voltage	Description
224	CODEC_INR	I	2.7V	CODEC Right channel Line In.
225	I2S/AC97_RX (uP_SRXD1)	I	1.8V	I2S data Receive signal.
226	CODEC_OUTL	O	2.7V	CODEC Left channel Line Out.
227	I2S/AC97_TX (uP_STXD1)	O	1.8V	I2S data Transmit signal.
228	CODEC_OUTR	O	2.7V	CODEC Right Channel Line Out.
229	DGND	I	GND	Ground. Connect to digital ground.
230	DGND	I	GND	Ground. Connect to digital ground.
231	RFU	I/O	NA	Reserved for future use. Do not connect.
232	RFU	I/O	NA	Reserved for future use. Do not connect.
233	RFU	I/O	NA	Reserved for future use. Do not connect.
234	RFU	I/O	NA	Reserved for future use. Do not connect.
235	RFU	I/O	NA	Reserved for future use. Do not connect.
236	RFU	I/O	NA	Reserved for future use. Do not connect.
237	RFU	I/O	NA	Reserved for future use. Do not connect.
238	RFU	I/O	NA	Reserved for future use. Do not connect.
239	RFU	I/O	NA	Reserved for future use. Do not connect.
240	RFU	I/O	NA	Reserved for future use. Do not connect.

6 Mechanical Specifications

6.1 Interface Connectors

The i.MX27 SOM-LV connects to a PCB baseboard through two 240-pin board-to-board (BTB) socket connectors.

Ref Designator	Manufacturer	SOM-LV Connector P/N	Mating Connector P/N
J1, J2	Samtec	BTH-120-01-L-D-A	BSH-120-01-L-D-A

6.2 Mounting Specifications

6.2.1 Support Spacers

Attach spacers between the SOM-LV and application board to provide additional support when securing the SOM-LV to the baseboard.

Manufacturer	PN	Description	Sales Info.
Bivar	9908-5MM	Nylon screw (#4) spacers, 5 mm	www.bivar.com/distributors.asp

6.2.2 Screw Size

Securing the SOM-LV to the baseboard requires screws of size 3 or smaller.

6.2.3 Washers

Only use flat washers with diameters of 3.8 mm or smaller when securing the SOM-LV to the baseboard. Any other washer type or size may result in cut traces or component and PCB damage leaving the SOM-LV inoperable.

IMPORTANT NOTE: Do not apply an excessive amount of torque when securing the SOM-LV to the baseboard. Using more torque than necessary may damage the SOM-LV.

6.3 i.MX27 SOM-LV Mechanical Drawings

Please see the following two pages for mechanical drawings of the i.MX27 SOM-LV and recommended baseboard footprint layout.